

Looking Back to Go Forward

Introduction – The Family’s Long Reach

The family unit is one of the most powerful groups we will ever belong to. Generations of family history exert powerful forces on everyday decisions and produce a variety of life experiences. A family’s way of “doing” life repeats itself from one generation to another, often with destructive consequences.

Growing in emotional and spiritual health demands examining our family history. One can then confront unhealthy generational patterns such as divorce, addictive behaviours, emotional and physical abuse, rebellion, and unstable relationships. Although difficult, *Looking Back to Go Forward* enables God to redeem your broken past so the future may be all He intended it to be.

The Bible – The Family

When the Bible speaks of the “family” it refers to the entire extended family over three or four generations. This includes brothers, sisters, parents, grandparents, uncles, aunts, cousins and others in the family tree. What happens in one generation often repeats itself in the next. Therefore, the consequences of actions and decisions in one generation affect those that follow.

Ex 20:4-6

“You shall not make for yourself an image in the form of anything in heaven above or on the earth beneath or in the waters below. ⁵ You shall not bow down to them or worship them; for I, the LORD your God, am a jealous God, punishing the children for the sin of the parents to the third and fourth generation of those who hate me, ⁶ but showing love to a thousand generations of those who love me and keep my commandments.”

Ex 34:6-7

“And he passed in front of Moses, proclaiming, “The LORD, the LORD, the compassionate and gracious God, slow to anger, abounding in love and faithfulness, ⁷ maintaining love to thousands, and forgiving wickedness, rebellion and sin. Yet he does not leave the guilty unpunished; he punishes the children and their children for the sin of the parents to the third and fourth generation.”

Unfortunately, it is impossible to erase the negative effects of our family tree. However, it is possible to examine the sinful nature of our biological family and invite the power of God to break the unhealthy patterns.

John 8:31

“If you hold to my teaching, you are really my disciples. ³² Then you will know the truth, and the truth will set you free.”

2 Cor 3:17

“Now the Lord is the Spirit, and where the Spirit of the Lord is, there is freedom.”

A Hope For The Future

The great news of Christianity is that your biological family does not determine your future. God does! When you accept Jesus as your Saviour you are “adopted” into the family of God and can live as a child of God.

1 John 3:1

“How great is the love the Father has lavished on us, that we should be called children of God!”

Although this reality is certain, it is not yet fully realized. The life-long process of becoming like Christ involves releasing our old patterns of life, and living as a transformed member of God’s family. (2 Cor 5:17; Eph 4:22-24). Through the power of the Holy Spirit, each person must look at their own brokenness and sinfulness, as well as that of their family and culture.

Looking Back to Go Forward

A Genogram is a family tree that examines family relationships and dynamics over two or three generations. What emerge are patterns you inherited that are either beneficial or unhealthy. Here is an example:

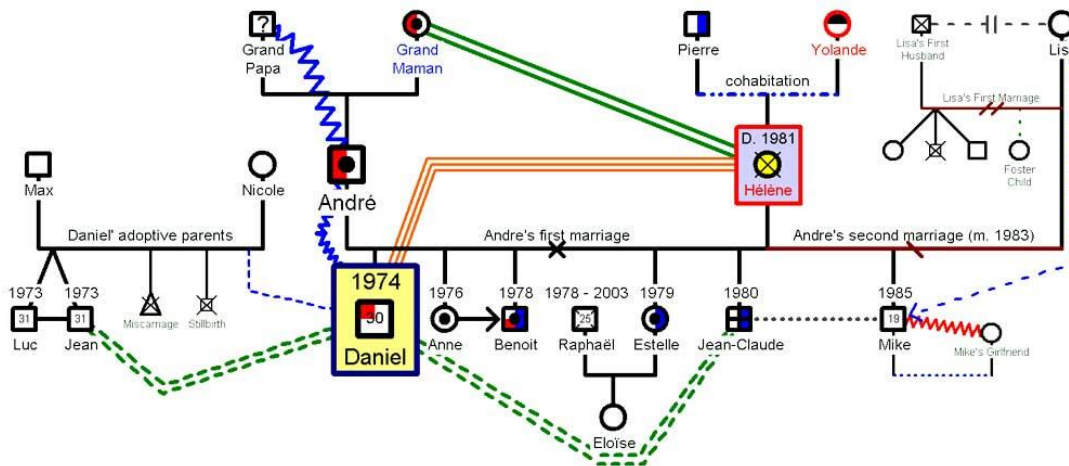

Create Your Genogram

You can construct a Genogram by hand using the below format and symbols, or programs found at <http://www.genopro.com>.

